

# Reach-in Freezer with 4 Glass Hinged Doors Model FGH96B and FGH96T

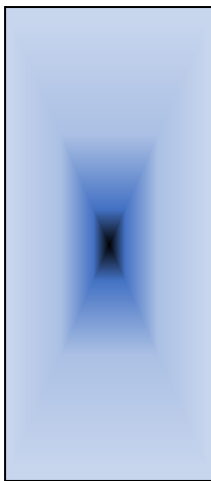
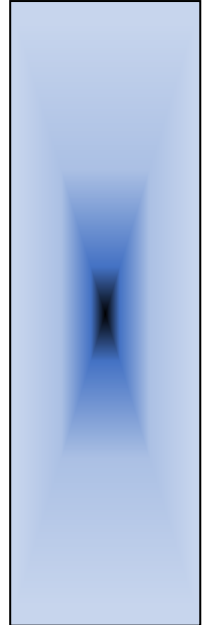

# Reach-in Freezer with 4 Glass Hinged Doors

## Model FGH96B and FGH96T

### Standard Features:

- Four **Tecnodor** reversible glass doors with high energy efficiency.
  - Operating temperature: 0°F to -10°F.
  - Exterior Dimensions: 96" x 30" x 82" high.
  - Door with thermal insulation double glazing.
  - Full length extruded aluminum handle.
  - Magnetic door gaskets.
  - Glass ensuring maximum visibility of the product.
  - Condensing unit assembled at the bottom for better maintenance and service accessibility (CGH96B).
  - Or: Condensing unit assembled at the top for better heat release (CGH96T).
  - Refrigerant: R404A.
  - Electronic temperature control, easy to read and adjust.
  - Automatic defrost.
  - Evaporation pan (no drain required).
- Self-closing door with stay open device to allow loading.
  - ETL Listed.
  - Door and frame in black satin finish.
  - Evaporator with slim design to ensure maximum interior space.
  - Capacity of 16 adjustable wire shelves and bottom section.
  - Self-contained, hermetic, air-cooled condensing unit (compressor).
  - Interior and exterior in high quality white polyester prepainted steel.
  - Insulated tub in polyurethane foam, high density, foamed-in-place, CFC free.
  - Fluorescent interior lighting (T8).

### Options:

- Interior/exterior finish in type 304 stainless steel finish #4.
- Additional shelf.
- DEL Interior lighting.
- Choice of finish colors (Sico palette).
- Condensing unit (compressor) with remote installation.

Model	Voltage	Total Amps
FGH96B	120/240 Volts	3.80/19.3 Amps
FGH96T	120/240 Volts	3.80/19.3 Amps

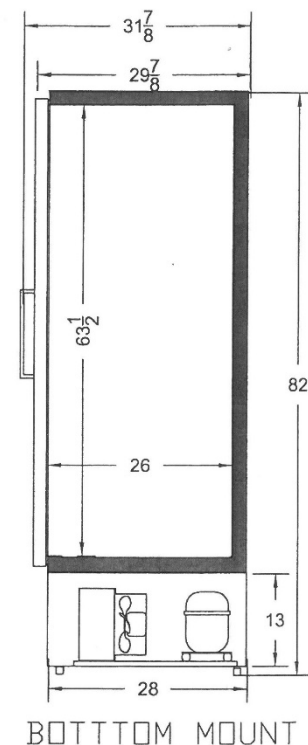
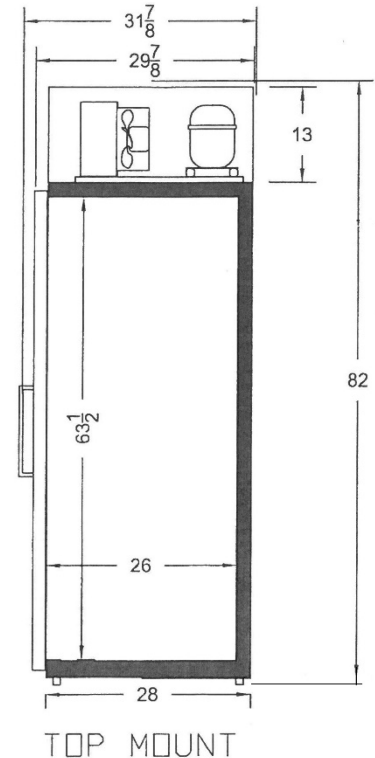

Designed for operation at an ambient temperature of 75°F and 55% relative humidity.  
Specifications subject to change without notice. (Rev. 28-10-2020)